

EuroVan - Standard Equipment

from December 2000

Deviate relay location and fuseplacements as well as the locations of multiple connectors see section "component locations".

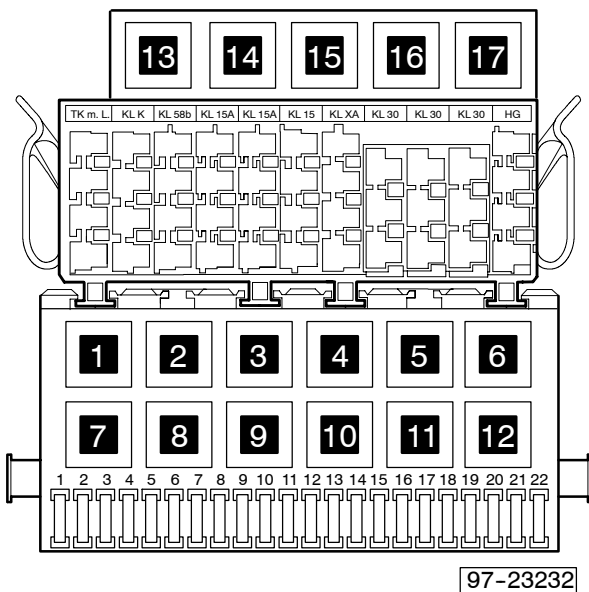

- 2** Rear Window Wiper/Washer Relay (174)
- 4** Load Reduction Relay (18)
- 5** Wire distributor for Data-Bus
- 8** Wiper/Washer Intermittent Relay (programmable) (99)
- 11** Dual Horn Relay (53)
- 17** Load Reduction Relay II (53)

Note: Number in parentheses indicates production control number stamped on relay housing.

Fuse colors

- 30 A - green
- 25 A - white
- 20 A - yellow
- 15 A - blue
- 10 A - red
- 7,5 A - brown
- 5 A - beige
- 3 A - violet

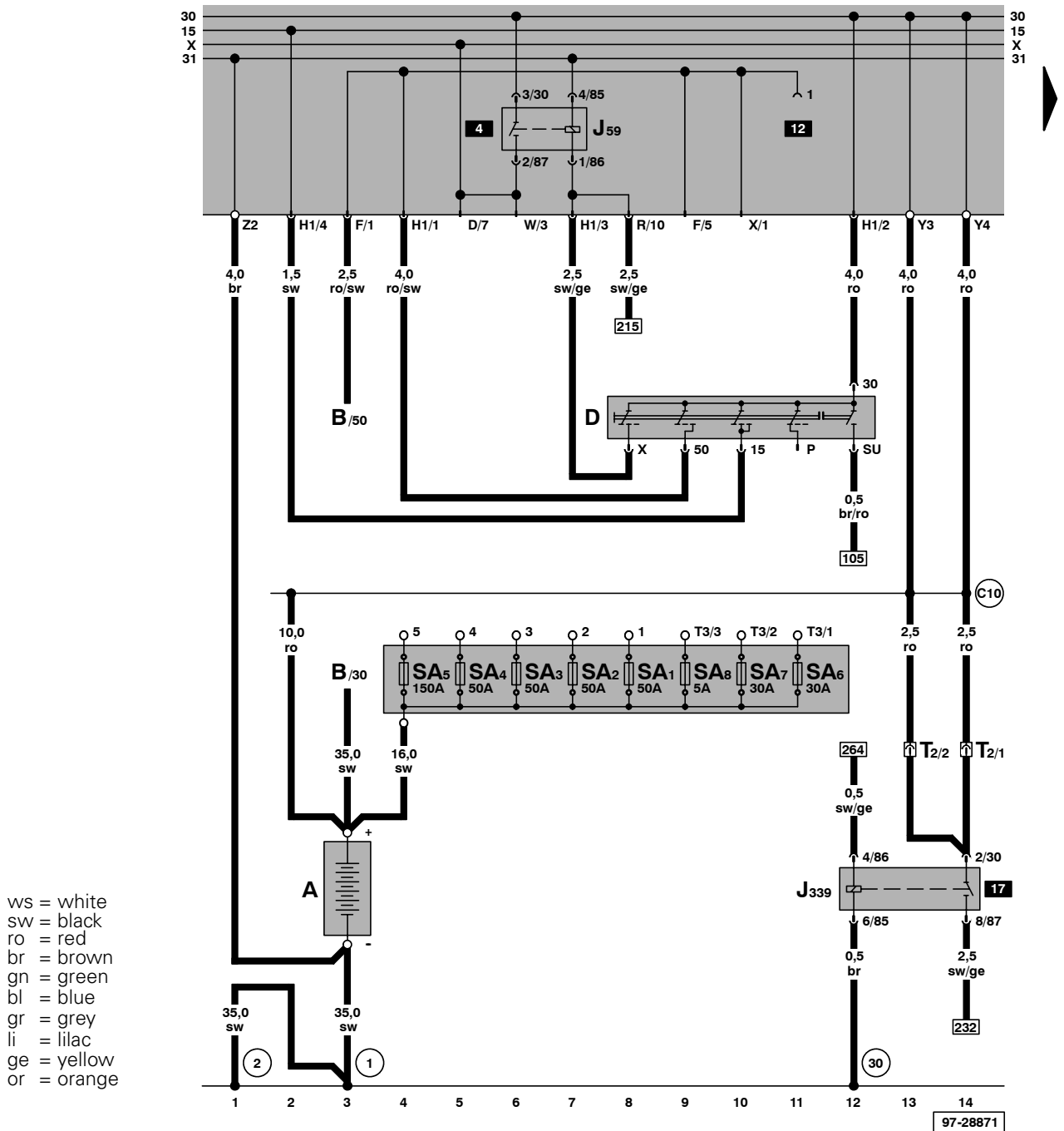

ws = white
sw = black
ro = red
br = brown
gn = green
bl = blue
gr = grey
li = lilac
ge = yellow
or = orange

- A - Battery
- B - Starter
- D - Ignition/Starter Switch
- J59 - Load Reduction Relay
- J339 - Load Reduction Relay II, above fuse/relay panel
- SA1 - Fuse -1- in fuse bracket/battery
- SA2 - Fuse -2- in fuse bracket/battery
- SA3 - Fuse -3- in fuse bracket/battery
- SA4 - Fuse -4- in fuse bracket/battery
- SA5 - Fuse -5- in fuse bracket/battery
- SA6 - Fuse -6- in fuse bracket/battery
- SA7 - Fuse -7- in fuse bracket/battery
- SA8 - Fuse -8- in fuse bracket/battery
- T2 - Double Connector, behind fuse/relay panel
- T3 - 3-Pin Connector

- 1 - Ground strap, battery to body
- 2 - Ground strap, transmission to body
- 30 - Ground connection, -1-, beside fuse/relay panel
- C10 - Plus connection -1- (30), in headlight wiring harness

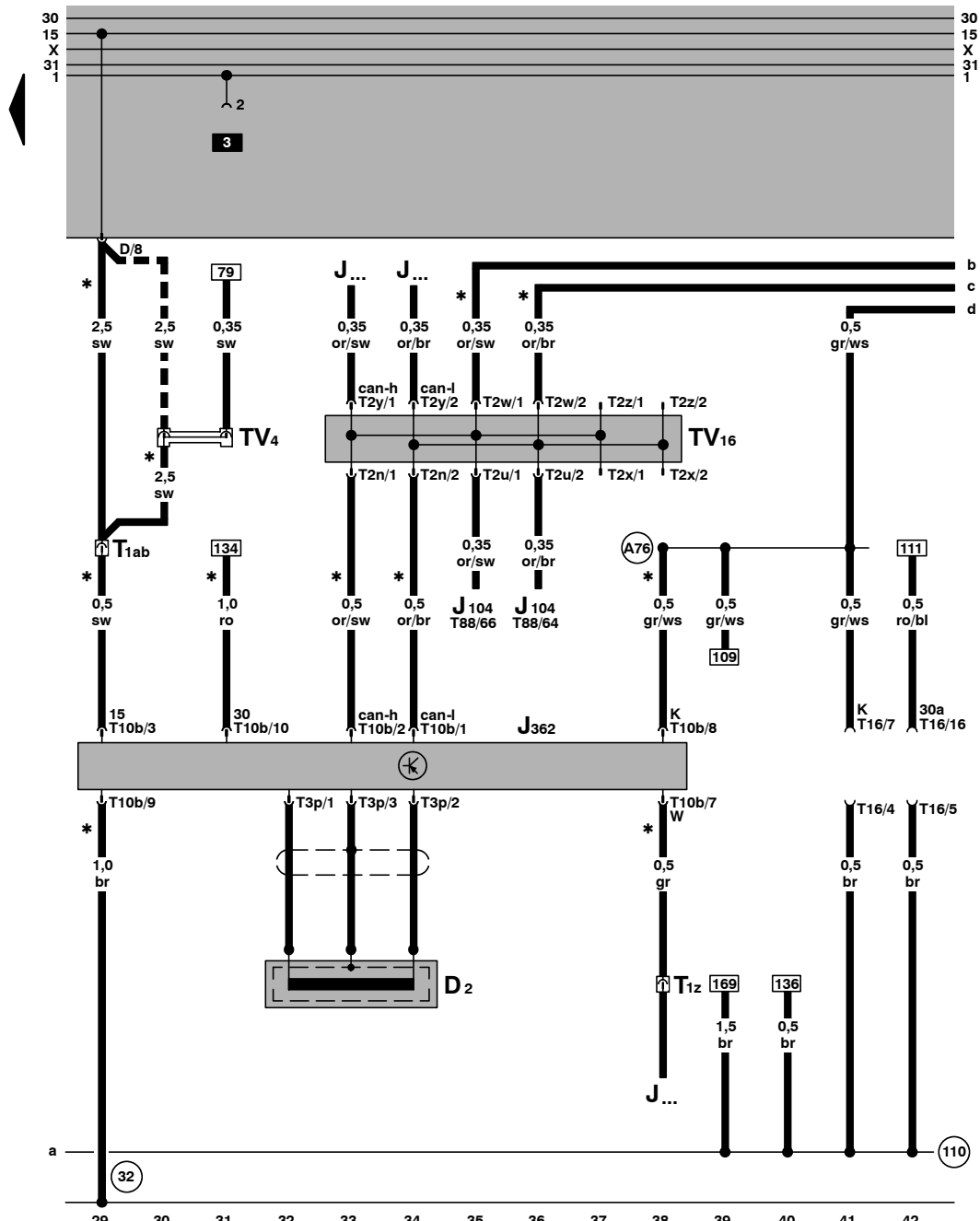

ws = white
 sw = black
 ro = red
 br = brown
 gn = green
 bl = blue
 gr = grey
 li = lilac
 ge = yellow
 or = orange

- D2 - Induction coil of antitheft immobilizer*
- J... - Engine Control Module (ECM)
- J104 - ABS Control Module (with EDL)
- J362 - Control module for anti-theft immobilizer, behind instrument cluster, right*
- T1ab - Single Connector, behind fuse/relay panel
- T1z - Single Connector, behind fuse/relay panel
- T2n - Double Connector
- T2u - Double Connector
- T2w - Double Connector
- T2x - Double Connector
- T2y - Double Connector
- T2z - Double Connector
- T3p - 3-Pin Connector
- T10b - 10-Pin Connector
- T16 - Data Link Connector (DLC), behind steering column cover

- T88 - 88-Pin Connector (vehicles with ESP only)
- TV4 - Terminal 15 Wire Connector, black
- TV16 - Wire distributor for Data-Bus, on relay panel No. 5
- (32) - Ground connection, behind instrument panel, left
- (110) - Ground connection -2-, in instrument panel wiring harness
- (A76) - Connector (K-diagnosis wire) in instrument panel wiring harness

- * - Vehicles with antitheft immobilizer
- - Vehicles without antitheft immobilizer

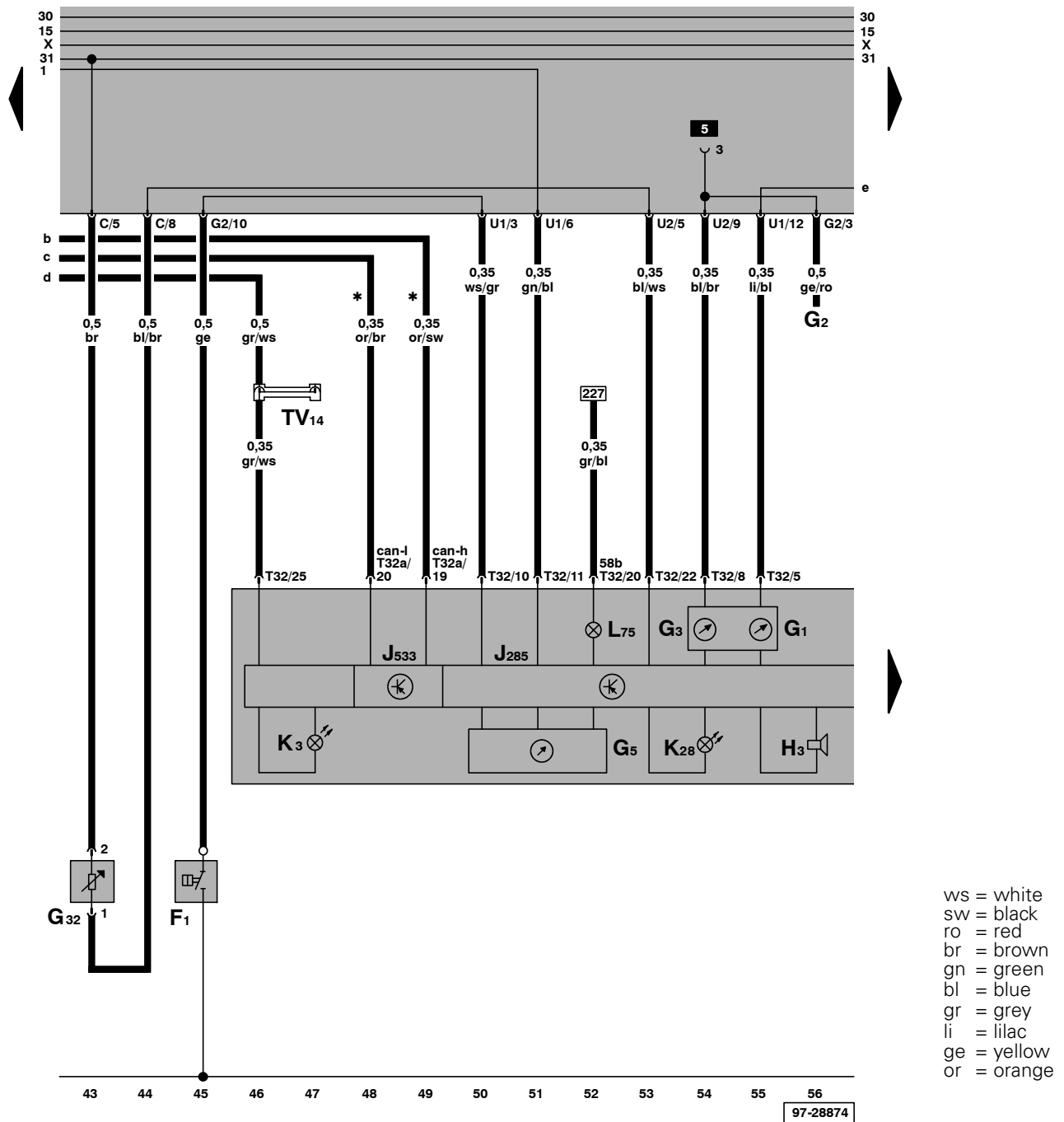

- F1 - Oil Pressure Switch
- G1 - Fuel Gauge
- G2 - Engine Coolant Temperature (ECT) Sensor
- G3 - Engine Coolant Temperature (ECT) Gauge
- G5 - Tachometer
- G32 - Engine Coolant Level (ECL) Sensor
- H3 - Warning Buzzer
- J285 - Control module with indicator unit in instrument panel insert
- J533 - Data Bus On Board Diagnostic Interface
- K3 - Oil Pressure Warning Light
- K28 - Engine Coolant Level/Temperature (ECL/ECT) Warning Light
- L75 - Digital Display Light
- T32 - 32-Pin Connector, blue
- T32a - 32-Pin Connector, green

TV14 - Data Link Connector (DLC) wire Connector, white

* - Vehicles with antitheft immobilizer

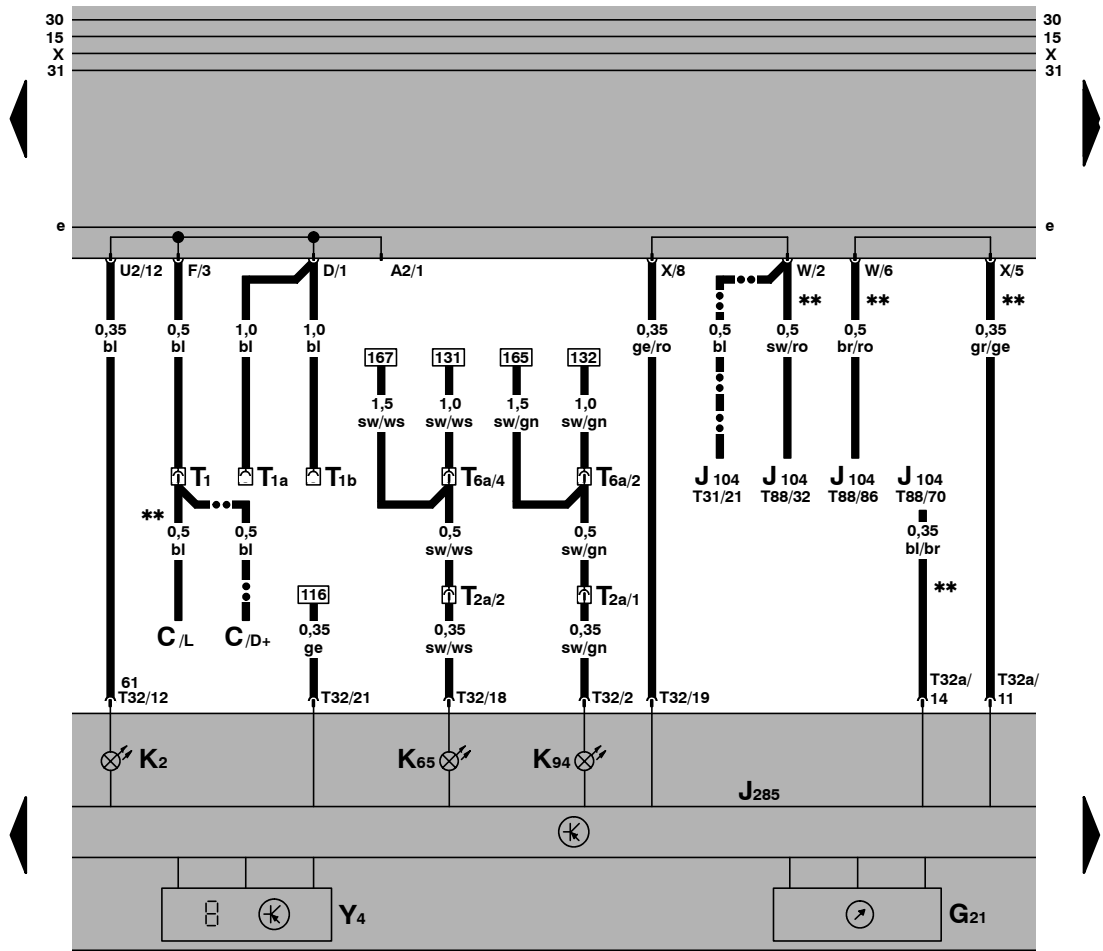

ws = white
 sw = black
 ro = red
 br = brown
 gn = green
 bl = blue
 gr = grey
 li = lilac
 ge = yellow
 or = orange

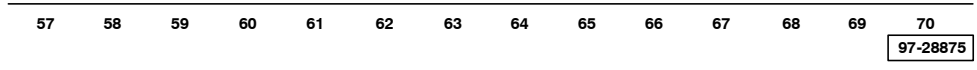

- C - Generator (GEN)
- G21 - Speedometer
- J104 - ABS Control Module (w/EDL), in engine compartment, left (through November 2000)
- J104 - ABS Control Module (with EDL), below instrument panel, right**
- J285 - Control module with indicator unit in instrument panel insert
- K2 - Generator (GEN) Warning Light
- K65 - Left Turn Signal Indicator Light
- K94 - Right Turn Signal Indicator Light
- T1 - Single Connector, near starter
- T1a - Single Connector, behind fuse/relay panel
- T1b - Single Connector, behind fuse/relay panel
- T2a - Double Connector, behind fuse/relay panel
- T6a - 6-Pin Connector, behind fuse/relay panel
- T31 - 31-Pin Connector, on ABS Control Module (w/EDL) (through November 2000)
- T32 - 32-Pin Connector, blue
- T32a - 32-Pin Connector, green
- T88 - 88-Pin Connector at -J104-
- Y4 - Odometer Display
- ** - Beginning December 2000
- .-.- - Through November 2000

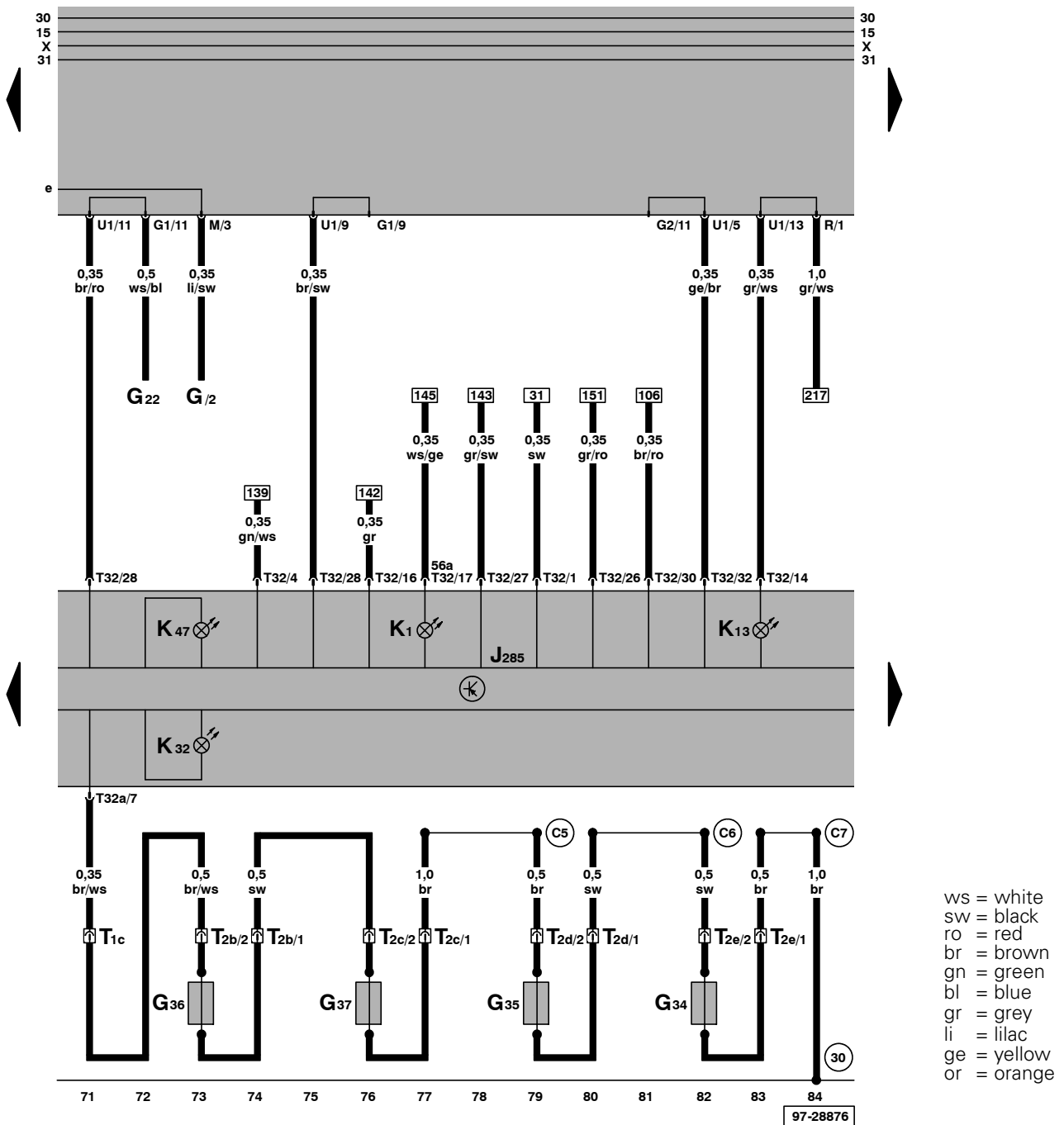

- G - Fuel Level Sensor
 G22 - Speedometer Vehicle Speed Sensor (VSS)
 G34 - Left Front Brake Pad Wear Sensor
 G35 - Right Front Brake Pad Wear Sensor
 G36 - Left Rear Brake Pad Wear Sensor
 G37 - Right Rear Brake Pad Wear Sensor
 J285 - Control module with indicator unit in instrument panel insert
 K1 - Headlight High Beam Indicator Light
 K13 - Rear Fog Light Indicator Light
 K32 - Brake Pad Wear Indicator Light
 K47 - ABS Warning Light
 T1c - Single Connector, behind fuse/relay panel
 T2b - Double Connector, near left rear brake pad wear sensor

- T2c - Double Connector, near right rear brake pad wear sensor
 T2d - Double Connector, near right front brake pad wear sensor
 T2e - Double Connector, near left front brake pad wear sensor
 T32 - 32-Pin Connector, blue
 T32a - 32-Pin Connector, green
 (30) - Ground connection, -1-, beside fuse/relay panel
 (C5) - Wire connection -1- (brake pad wear monitor), in left front wiring harness
 (C6) - Wire connection -2- (brake pad wear monitor), in left front wiring harness
 (C7) - Wire connection -3- (brake pad wear monitor), in left front wiring harness

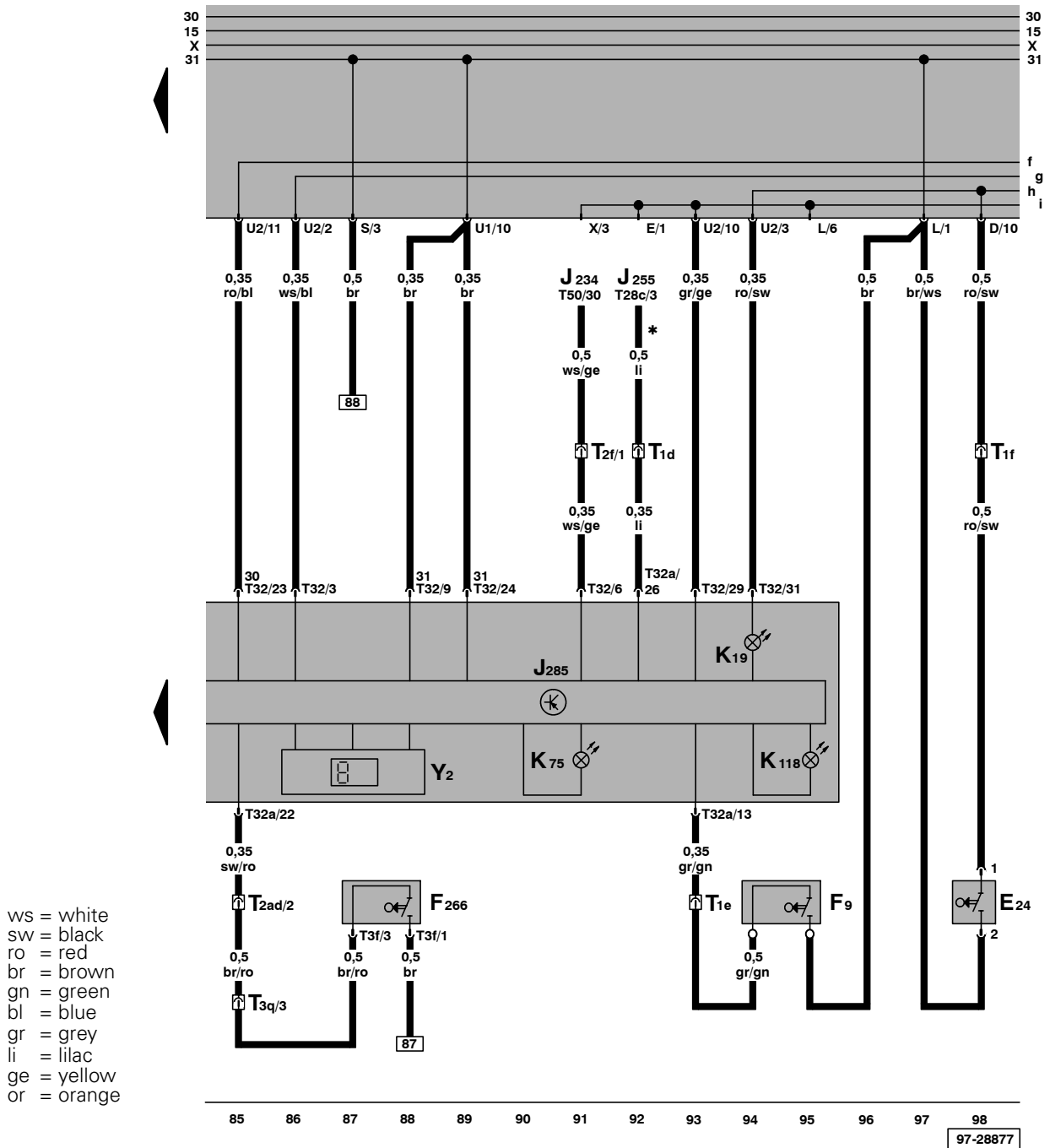

- E24 - Left Seat Belt Switch
- F9 - Parking Brake Warning Light Switch
- F266 - Front Hood Switch
- J234 - Airbag Control Module
- J255 - Climatronic Control Module
- J285 - Control module with indicator unit in instrument panel insert
- K19 - Seat Belt Warning Light
- K75 - Airbag Malfunction Indicator Lamp (MIL)
- K118 - Warning light for brake system
- T1d - Single Connector, behind fuse/relay panel
- T1e - Single Connector, behind fuse/relay panel
- T1f - Single Connector, behind fuse/relay panel
- T2ad - Double Connector, behind fuse/relay panel
- T2f - Double Connector, behind fuse/relay panel
- T3f - 3-Pin Connector
- T3q - 3-Pin Connector, behind fuse/relay panel
- T32 - 32-Pin Connector, blue
- T32a - 32-Pin Connector, green
- T50 - 50-Pin Connector, on airbag control module
- Y2 - Digital Clock
- * - Vehicles with Climatronic only

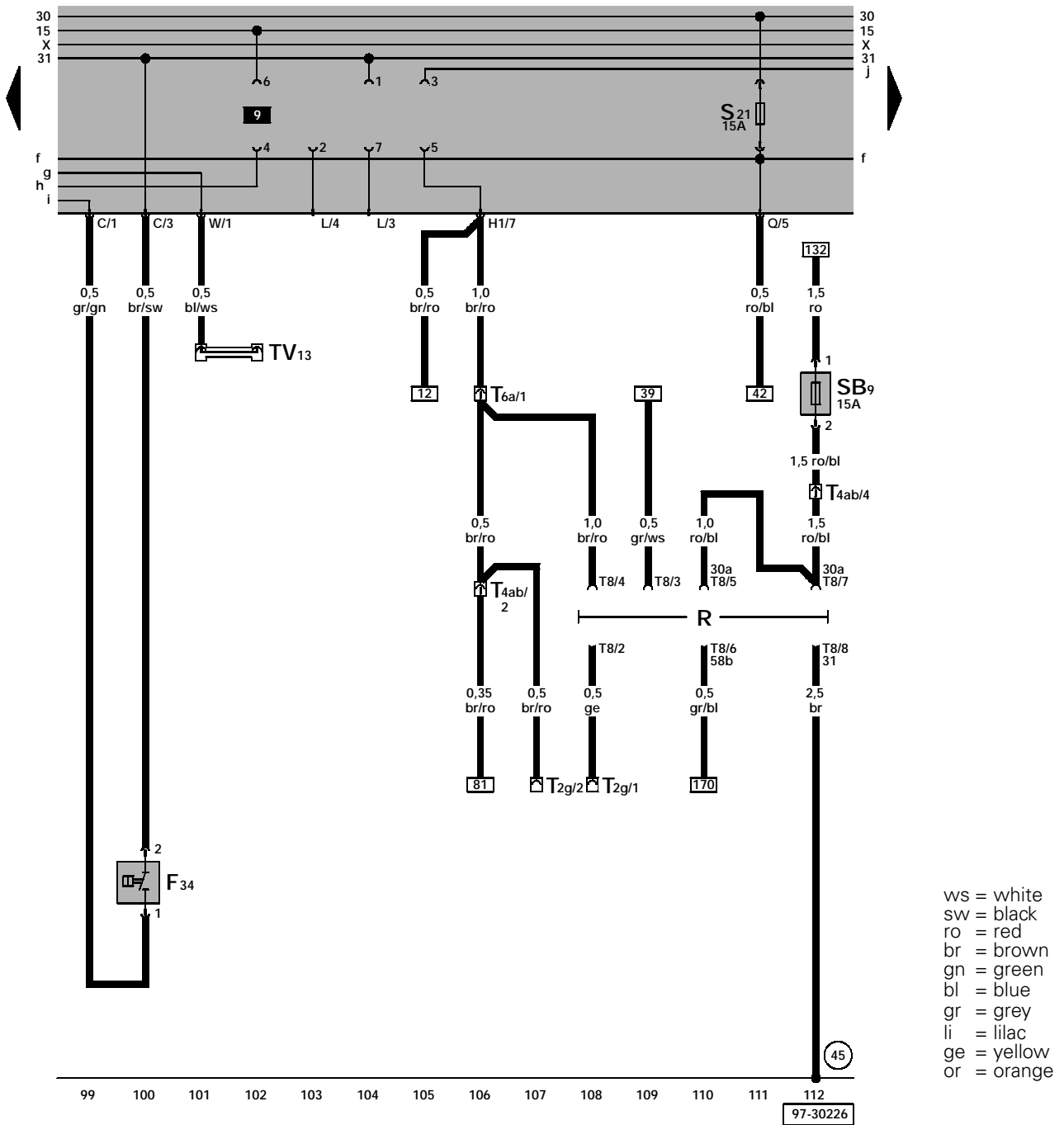

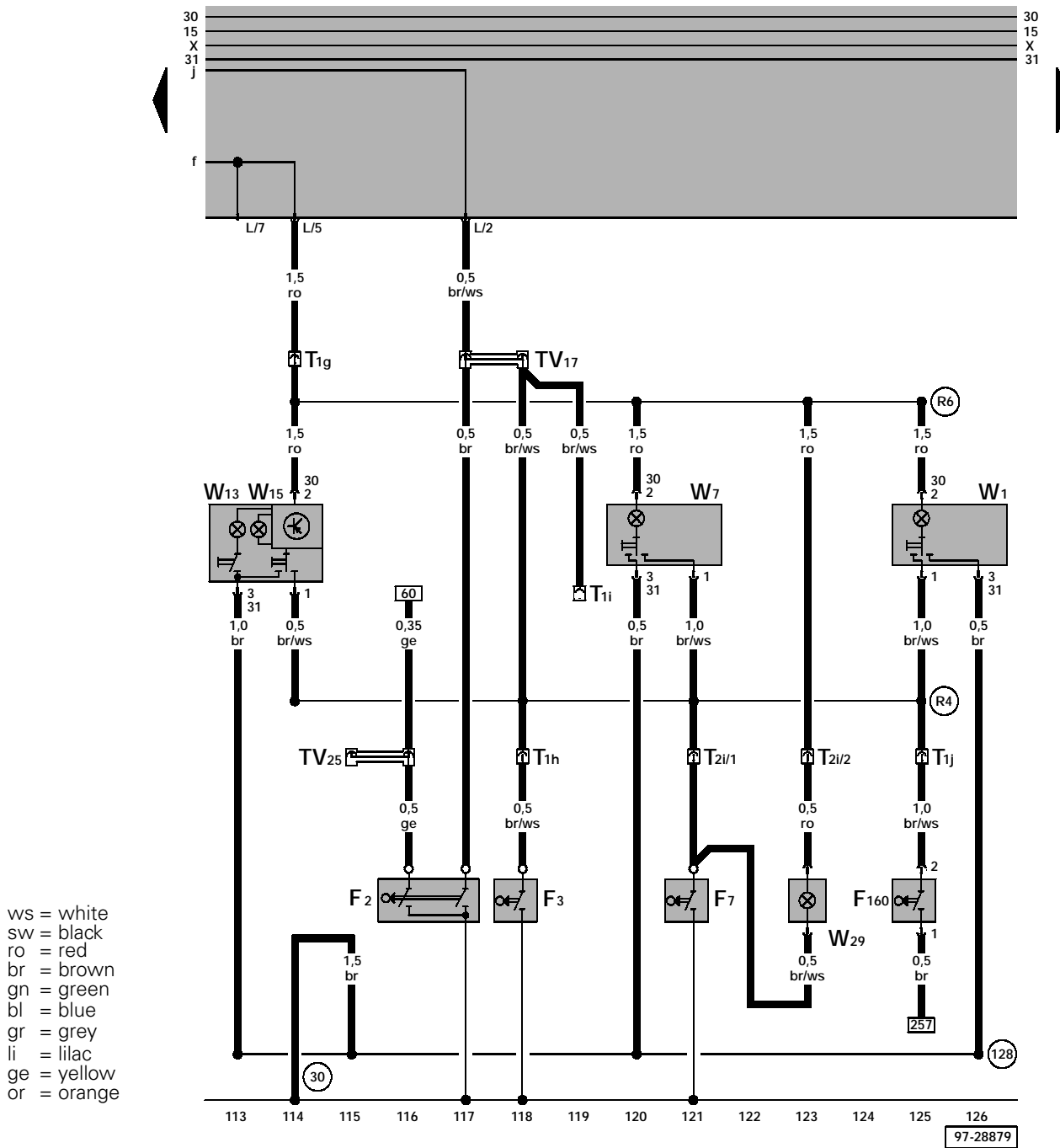

- F2 - Door contact Switch - Driver's side
- F3 - Door contact switch-Passenger side
- F7 - Right Rear Side/Sliding Door Contact Switch
- F160 - Rear Lid Contact Switch
- T1g - Single Connector, behind fuse/relay panel
- T1h - Single Connector, behind instrument panel, right
- T1i - Single Connector, behind fuse/relay panel
- T1j - Single Connector, near taillamp assembly
- T2i - Double Connector, near interior light, center
- TV17 - Door Contact Switch Wire Connector, brown
- TV25 - Door Contact Switch Wire Connector, pink
- W1 - Interior light, front
- W7 - Center Interior Light
- W13 - Right Front Map/Reading Light
- W15 - Interior Light with Delay Switch

W29 - Running board light

- (30) - Ground connection -1-, beside fuse/relay panel
- (128) - Ground connection -1-, in interior light wiring harness
- (R4) - Wire connection -1-, in interior light/door contact switch wiring harness
- (R6) - Plus connection -1-, in interior light wiring harness

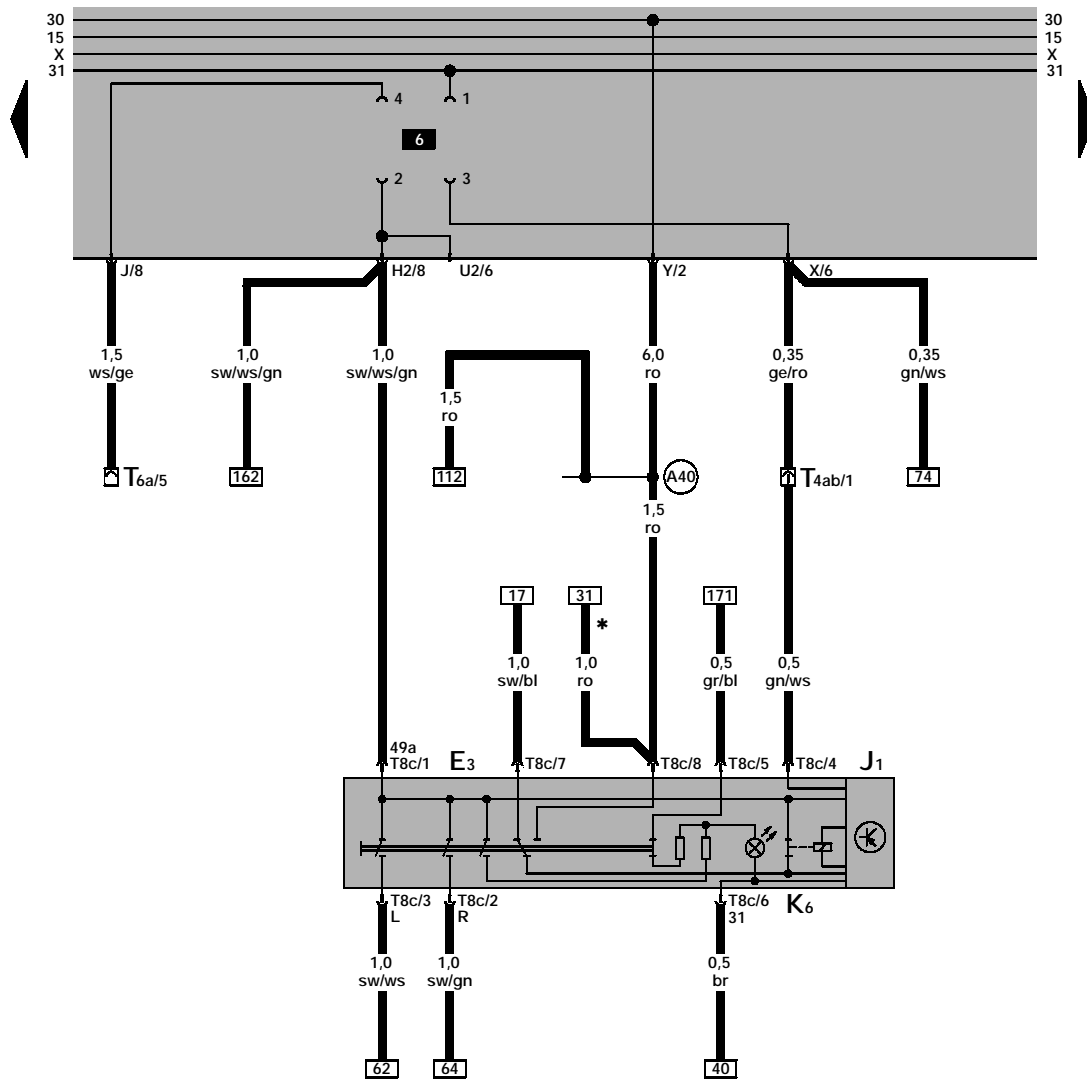

ws = white
 sw = black
 ro = red
 br = brown
 gn = green
 bl = blue
 gr = grey
 li = lilac
 ge = yellow
 or = orange

127 128 129 130 131 132 133 134 135 136 137 138 139 140
 97-30227

- E3 - Emergency Flasher Switch
- J1 - Turn Signal Relay
- K6 - Indicator light for emergency flasher system
- T4ab - 4-Pin Connector, behind fuse/relay panel
- T6a - 6-Pin Connector, behind fuse/relay panel
- T8c - 8-Pin Connector
- (A40) - Plus connection -1- (30), in instrument cluster wiring harness
- * - Vehicles with antitheft immobilizer

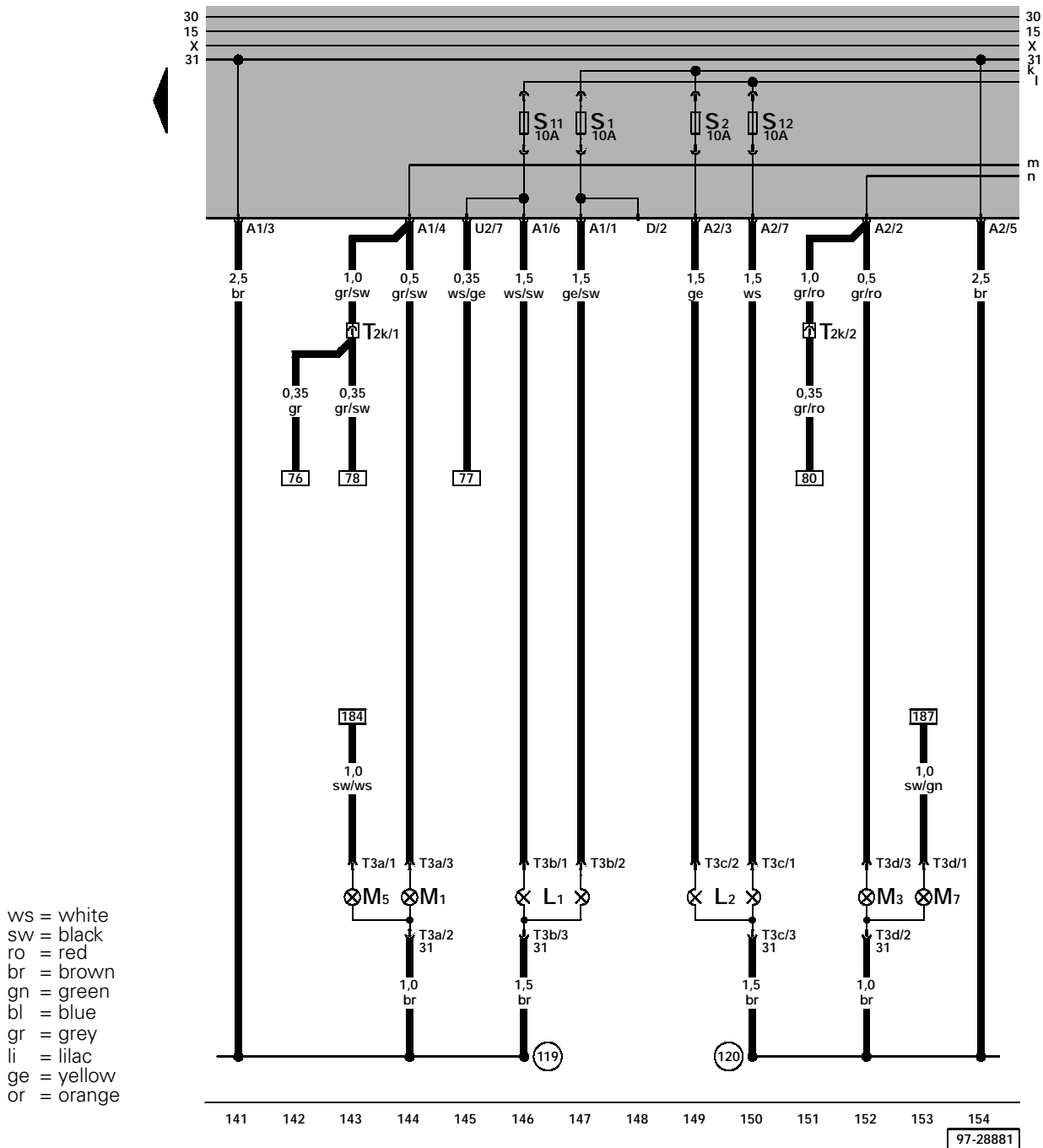

- L1 - Left Headlight
- L2 - Right Headlight
- M1 - Left Parking Light
- M3 - Right Parking Light
- M5 - Left Front Turn Signal Light
- M7 - Right Front Turn Signal Light
- T2k - Double Connector, behind fuse/relay panel
- T3a - 3-Pin Connector
- T3b - 3-Pin Connector
- T3c - 3-Pin Connector
- T3d - 3-Pin Connector

- (119) - Ground connection -1-, in headlight wiring harness
- (120) - Ground connection -2-, in headlight wiring harness

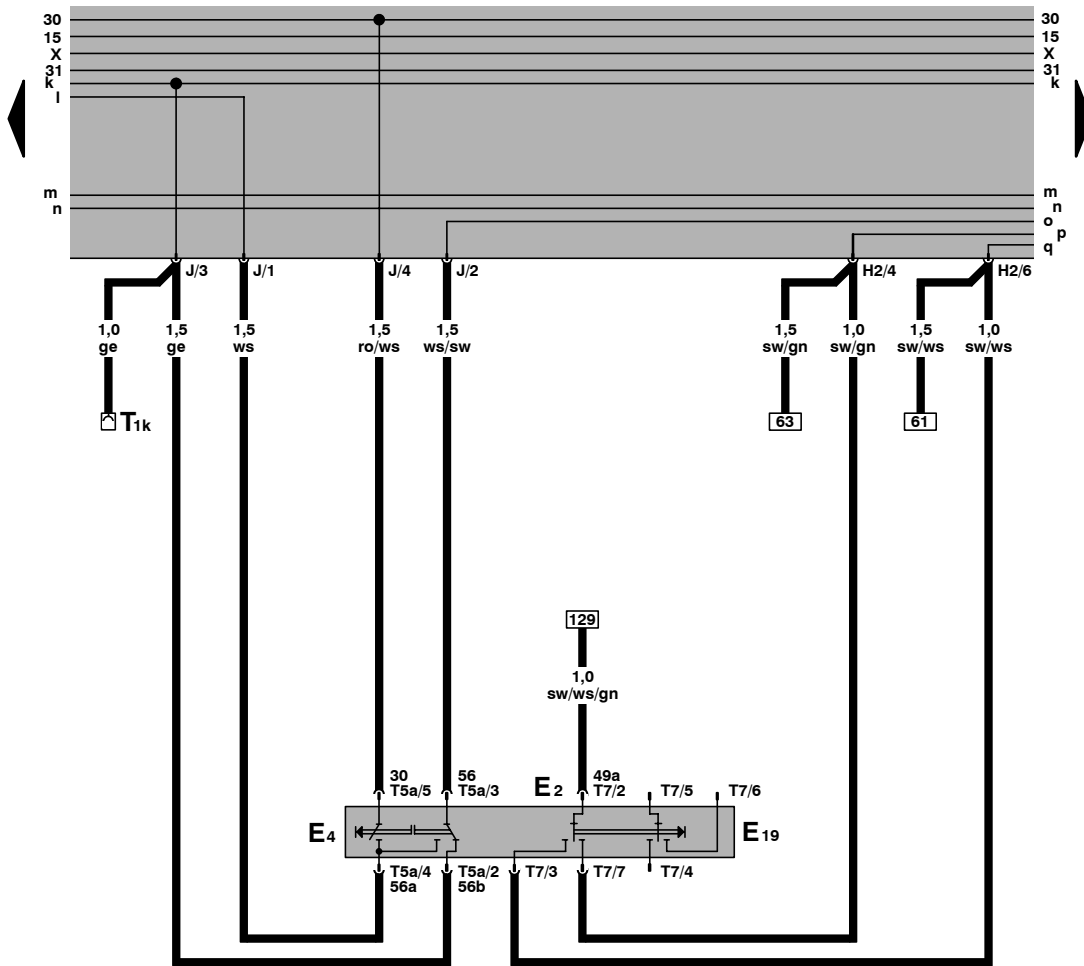

ws = white
 sw = black
 ro = red
 br = brown
 gn = green
 bl = blue
 gr = grey
 li = lilac
 ge = yellow
 or = orange

155	156	157	158	159	160	161	162	163	164	165	166	167	168
													97-28882

- E2 - Turn signal switch
- E4 - Headlight Dimmer/Flasher Switch
- E19 - Park Light Switch
- T1k - Single Connector, behind fuse/relay panel
- T5a - 5-Pin Connector, behind steering column switch cover
- T7 - 7-Pin Connector, behind steering column switch cover

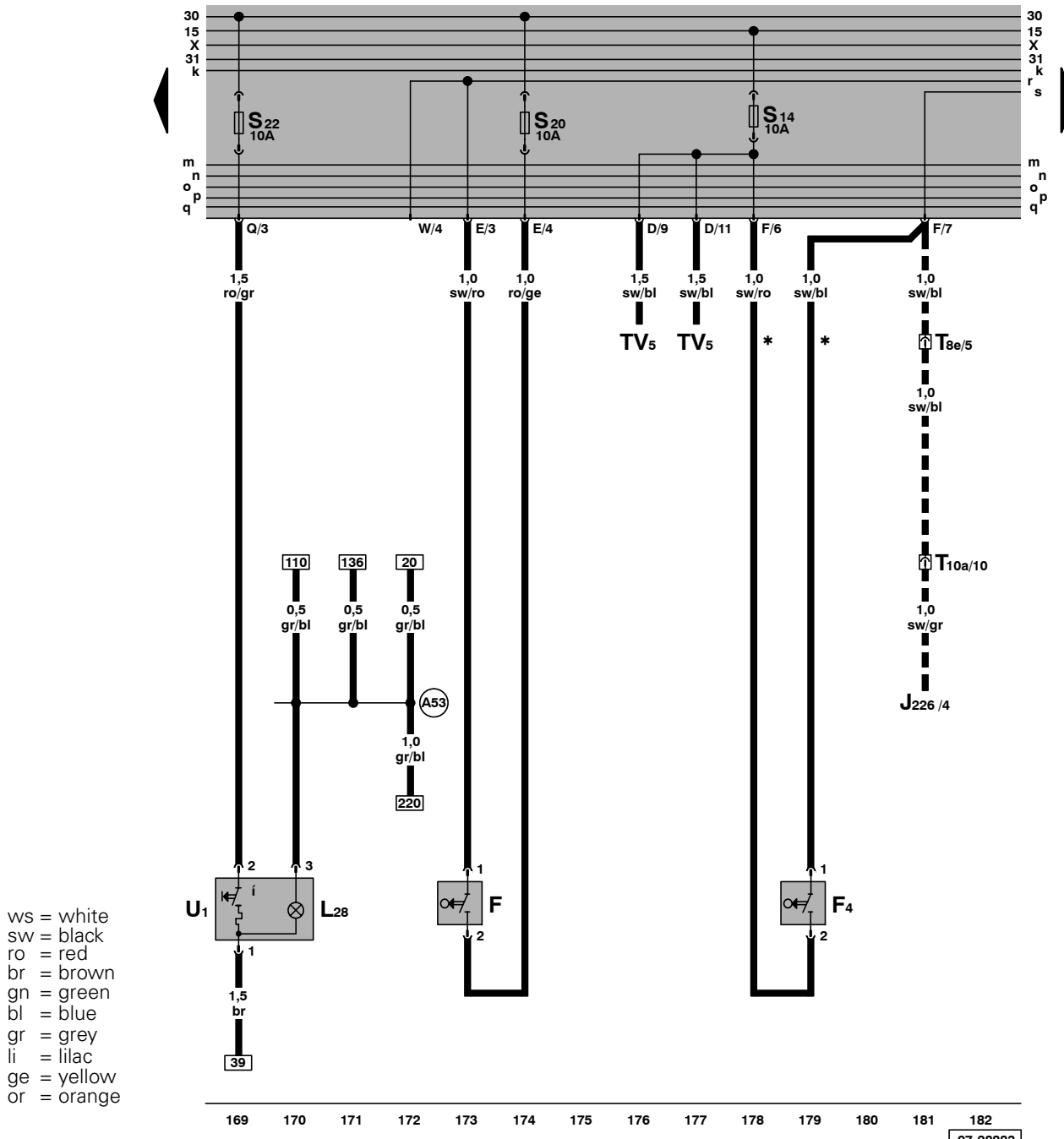

- F - Brake Light Switch
- F4 - Back-Up Light Switch*
- J226 - Park/Neutral Position (PNP) Relay
- L28 - Cigarette Lighter Light
- T8e - 8-Pin Connector, behind fuse/relay panel
- T10a - 10-Pin Connector, behind fuse/relay panel
- TV5 - Terminal 15a Wire Connector, green, 4-Pin and 8-Pin
- U1 - Cigarette Lighter
- (A53) - Plus connection (58b), in instrument panel wiring harness
- * - Manual transmission only
- - Automatic transmission only

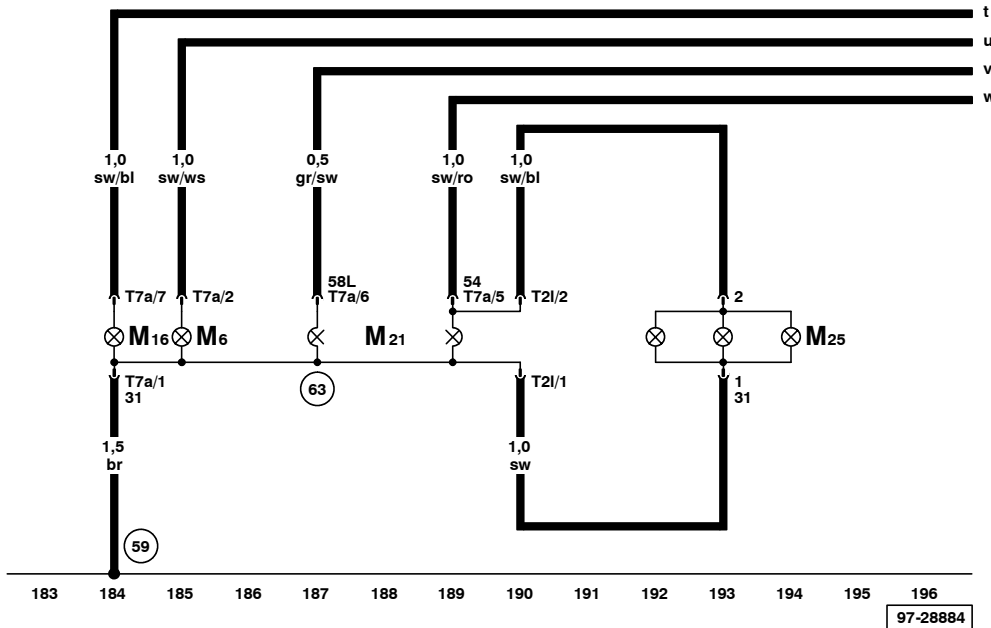
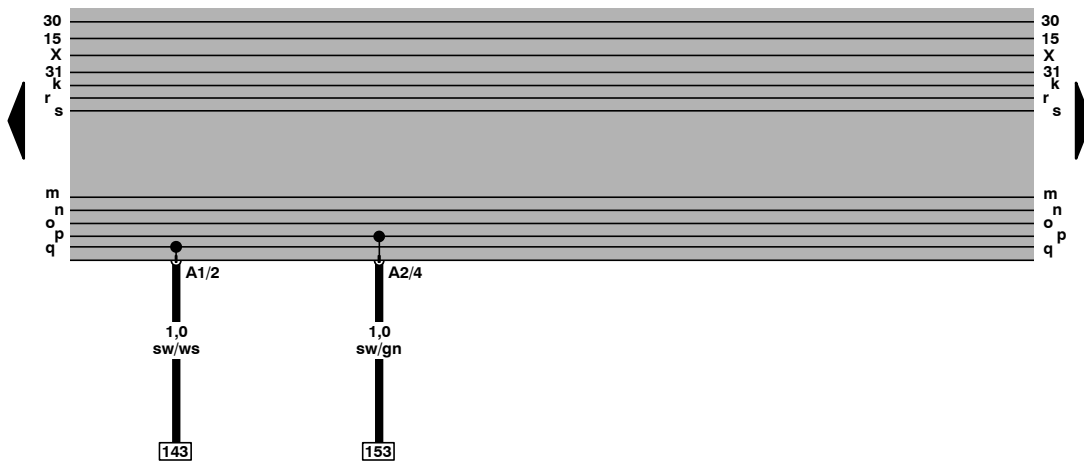

ws = white
 sw = black
 ro = red
 br = brown
 gn = green
 bl = blue
 gr = grey
 li = lilac
 ge = yellow
 or = orange

- M6 - Left Rear Turn Signal Light
- M16 - Left Back-Up Light
- M21 - Left Brake/Tail Light
- M25 - High-mount Brake Light
- T2l - Double Connector
- T7a - 7-Pin Connector

- (59) - Ground connection, near taillight, left
- (63) - Ground connection, on left taillight bulb holder

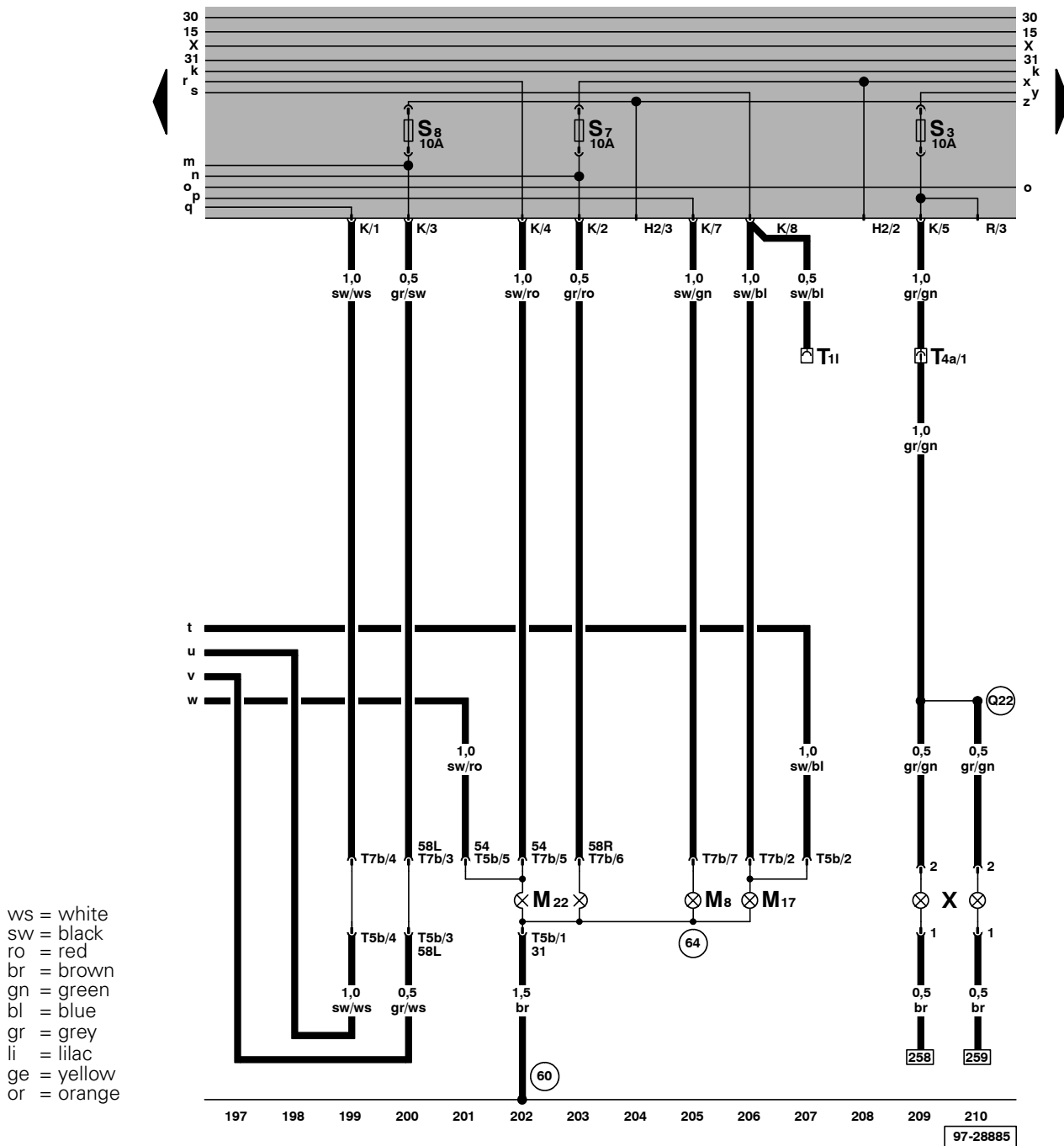

- M8 - Right Rear Turn Signal Light
- M17 - Right Back-Up Light
- M22 - Right Brake/Tail Light
- T11 - Single Connector, behind fuse/relay panel
- T4a - 4-Pin Connector, near taillamp assembly
- T5b - 5-Pin Connector
- T7b - 7-Pin Connector
- X - License Plate Light

- 60 - Ground point -2- near taillamp assembly, right
- 64 - Ground connection, on right taillight bulb holder
- Q22 - Wire connection -1-, in rear lid wiring harness

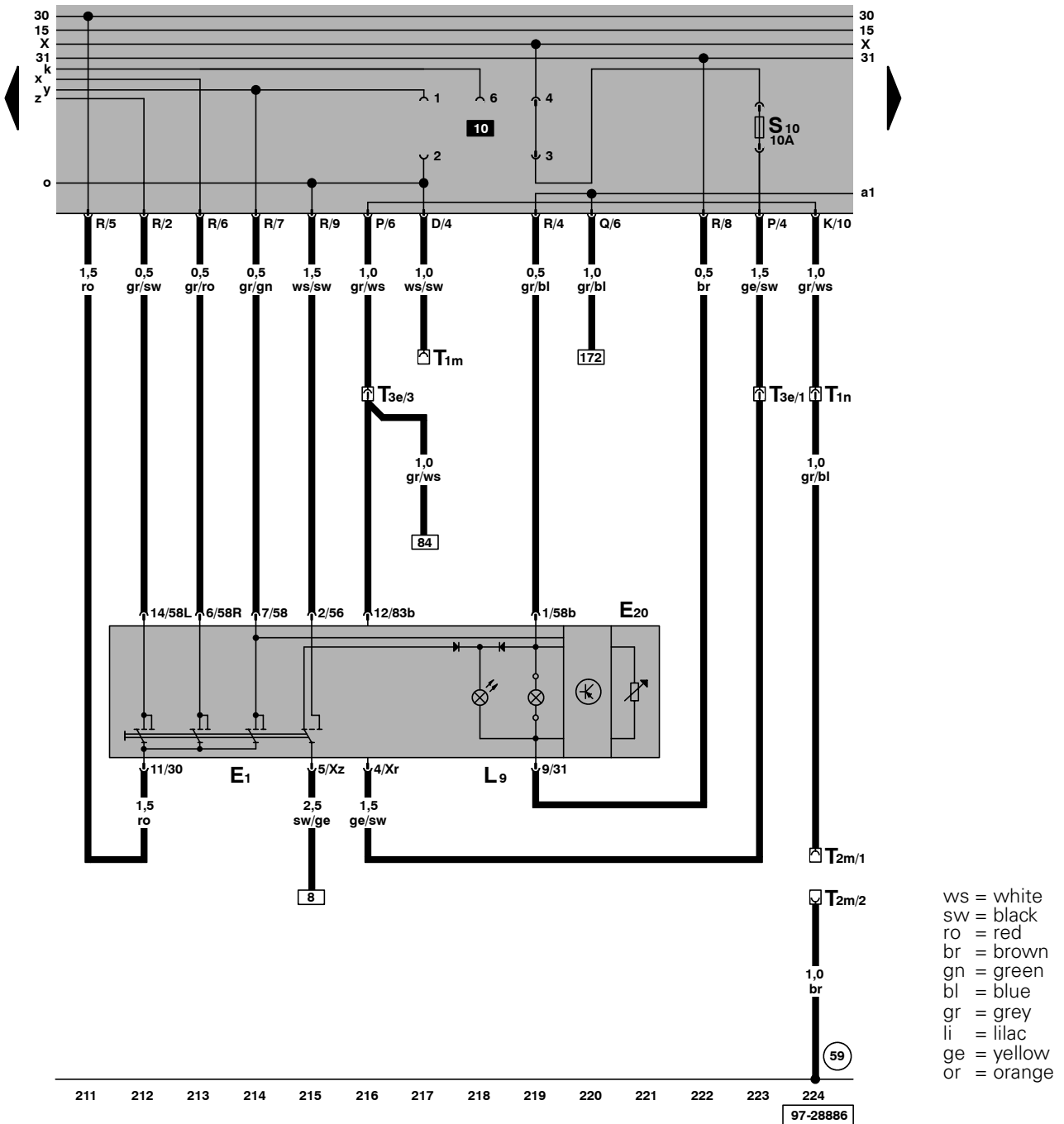

- E1 - Light switch
- E20 - Instrument Panel Light Dimmer Switch
- L9 - Headlight Switch Light
- T1m - Single Connector, behind fuse/relay panel
- T1n - Single Connector, near taillamp assembly
- T2m - Double Connector
- T3e - 3-Pin Connector, behind fuse/relay panel
- (59) - Ground connection, near taillight, left

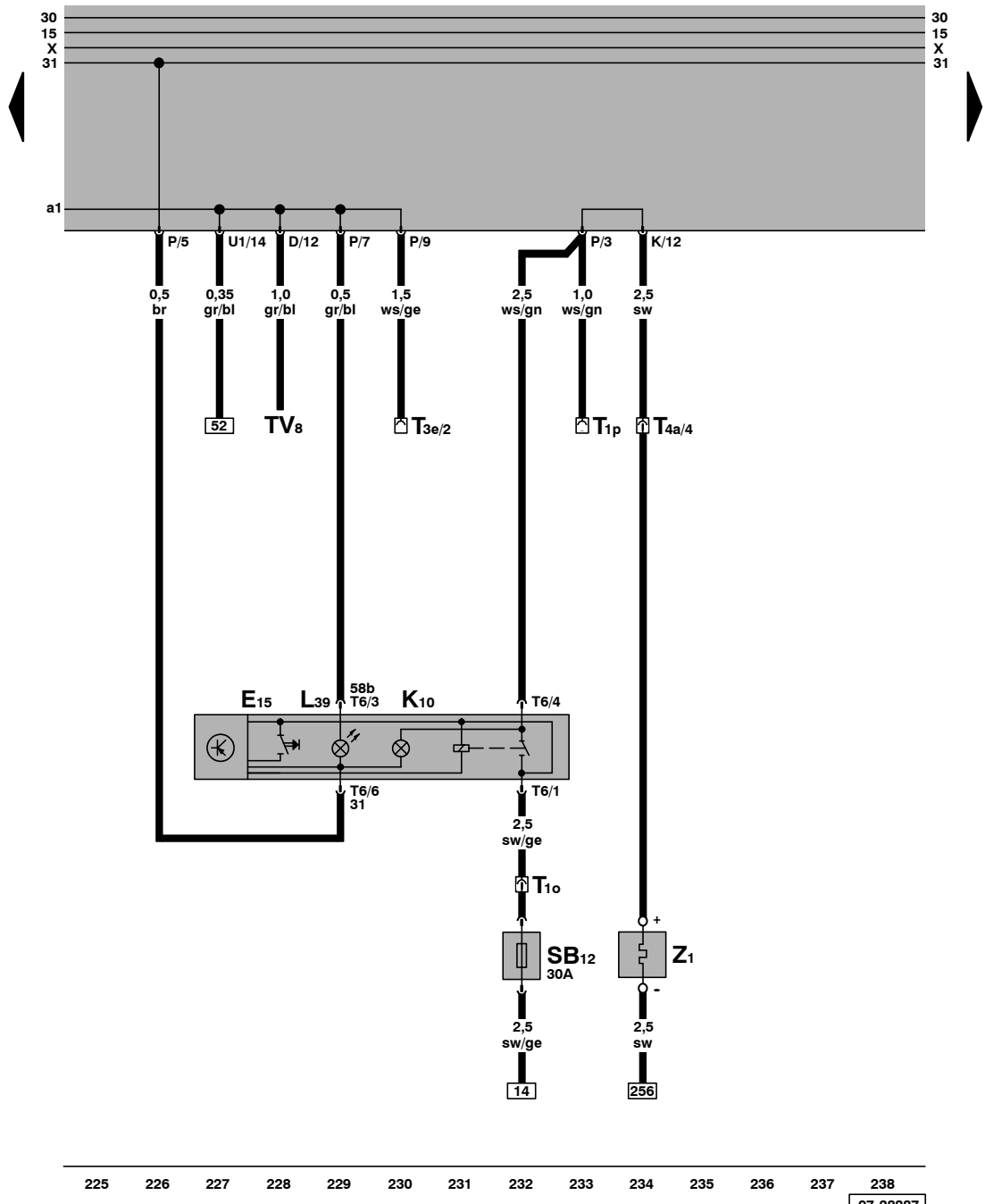

ws = white
 sw = black
 ro = red
 br = brown
 gn = green
 bl = blue
 gr = grey
 li = lilac
 ge = yellow
 or = orange

225 226 227 228 229 230 231 232 233 234 235 236 237 238
 97-28887

- E15 - Rear window defogger switch
- K10 - Indicator light for heated rear windshield
- L39 - Rear Window Defogger Switch Light
- SB12 - Fuse 12 in fuse holder, below relay panel
- T1o - Single Connector, behind fuse/relay panel
- T1p - Single Connector, behind fuse/relay panel
- T3e - 3-Pin Connector, behind fuse/relay panel
- T4a - 4-Pin Connector, near taillamp assembly
- T6 - 6-Pin Connector
- T6/3 - 6-Pin Connector
- T6/4 - 6-Pin Connector
- T6/6 - 6-Pin Connector
- TV8 - Terminal 58b Wire Connector, grey
- Z1 - Heated rear window

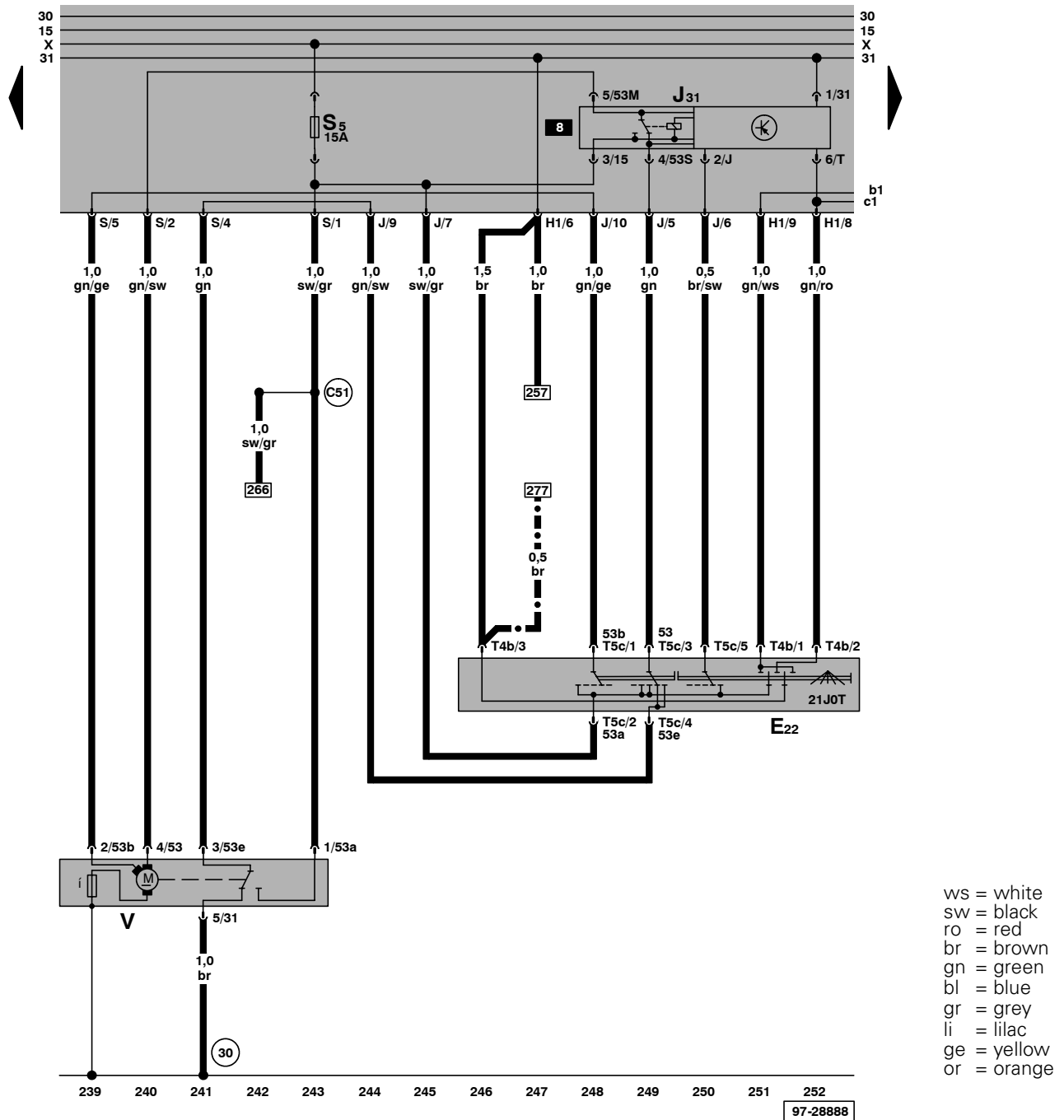

- E22 - Windshield Wiper/Washer Switch
- J31 - Wiper/Washer Intermittent Relay (programmable)
- T4b - 4-Pin Connector, behind steering column switch cover
- T5c - 5-Pin Connector, behind steering column switch cover
- V - Windshield Wiper Motor
- (30) - Ground connection, -1-, beside fuse/relay panel
- (C51) - Plus connection (x), in wiper motor wiring harness
- - Vehicles with electronic stability program (ESP) only

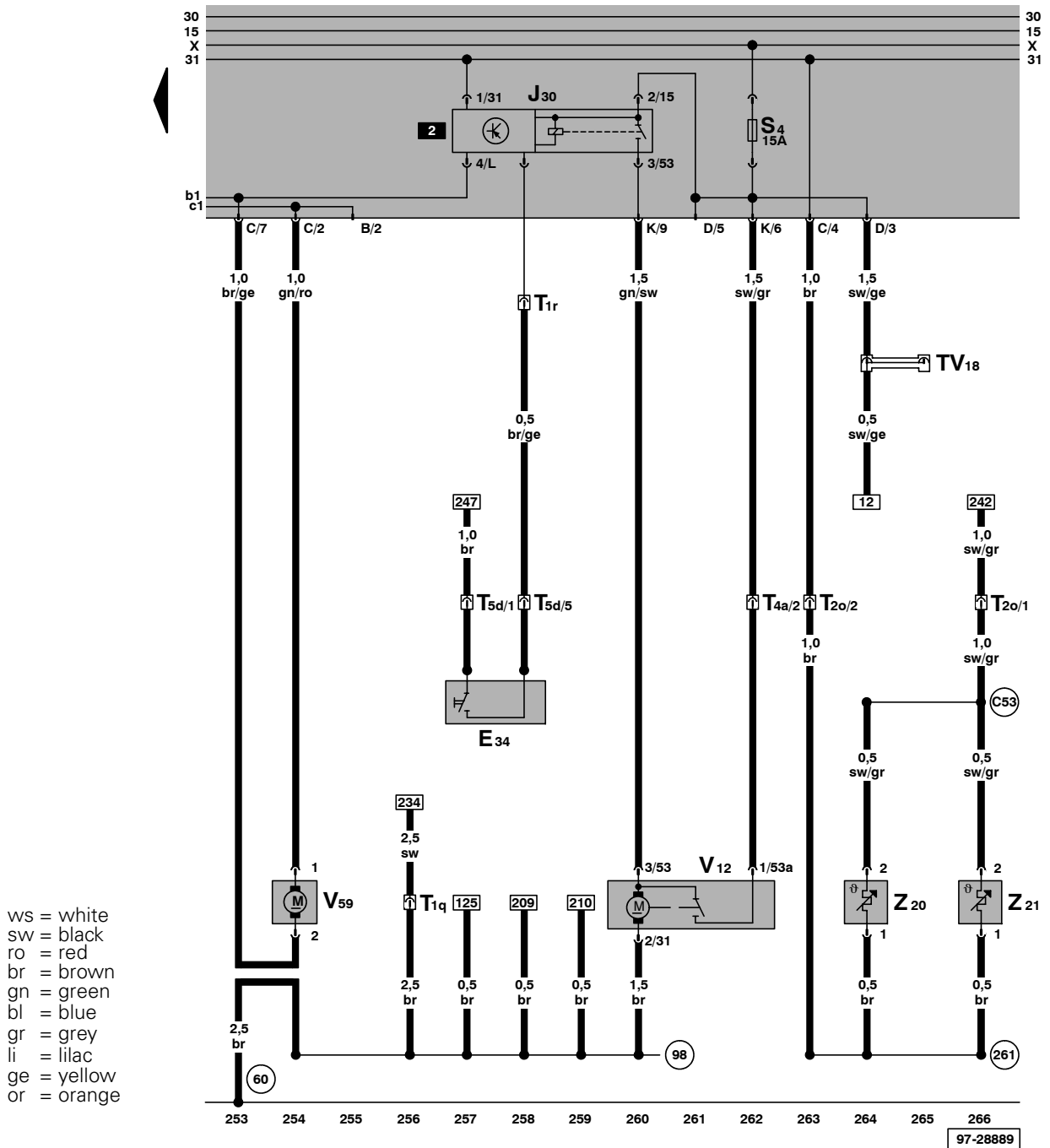

- E34 - Rear Window Wiper Switch
- J30 - Rear Window Wiper/Washer Relay
- T1q - Single Connector, in rear lid
- T1r - Single Connector, on rear window wiper/washer relay
- T2o - Double Connector, on firewall, right
- T4a - 4-Pin Connector, near taillamp assembly
- T5d - 5-Pin Connector, behind steering column switch cover
- TV18 - Terminal Xa Wire Connector, violet
- V12 - Motor for rear windshield wiper
- V59 - Windshield and Rear Window Washer Pump
- Z20 - Left Washer Nozzle Heater
- Z21 - Right Washer Nozzle Heater

- 60 - Ground point -2- near taillamp assembly, right
- 98 - Ground connection, in rear lid wiring harness
- 261 - Ground connection, in wiring harness heated spray jet
- C53 - Plus connection (x) in wiring harness heated spray jet

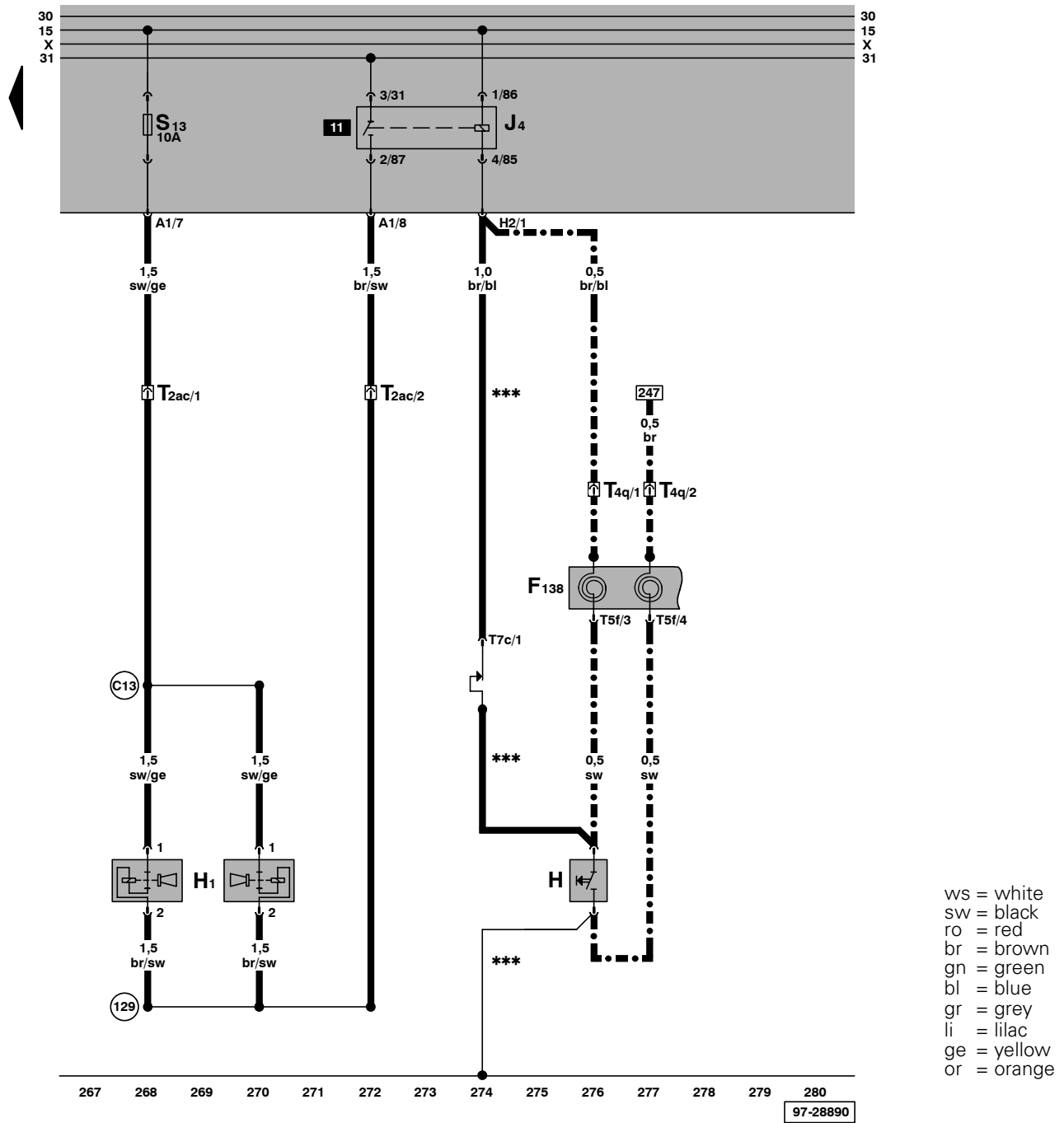

- F138 - Airbag Spiral Spring/Return Spring with Slip Ring
- H - Signal horn activation
- H1 - Dual tone horn
- J4 - Dual Horn Relay
- T2ac - Double Connector, in engine compartment, left front
- T4q - 4-Pin Connector, behind steering column switch cover
- T5f - 5-Pin Connector
- T7c - 7-Pin Connector, behind steering column switch cover

129 - Ground connection, in dual-tone horn wiring harness

C13 - Plus connection, in dual tone horn wiring harness

*** - Vehicles without electronic stability program (ESP) only

-.- - Vehicles with electronic stability program (ESP) only